



PATENTS ACT, 1978

CERTIFICATE

In accordance with section 44 (1) of the Patents Act, No. 57 of 1978, it is hereby certified that

MINTEK

has been granted a patent in respect of an invention described and claimed in complete specification deposited at the Patent Office under the number

2007/5597

A copy of the complete specification is annexed, together with the relevant Form P2.

In testimony thereof, the seal of the Patent Office has been affixed at Pretoria with effect

from the **25th** day of **June 2008**

A handwritten signature in cursive script, appearing to read 'J. Jacobs', written over a horizontal dotted line.

Registrar of Patents

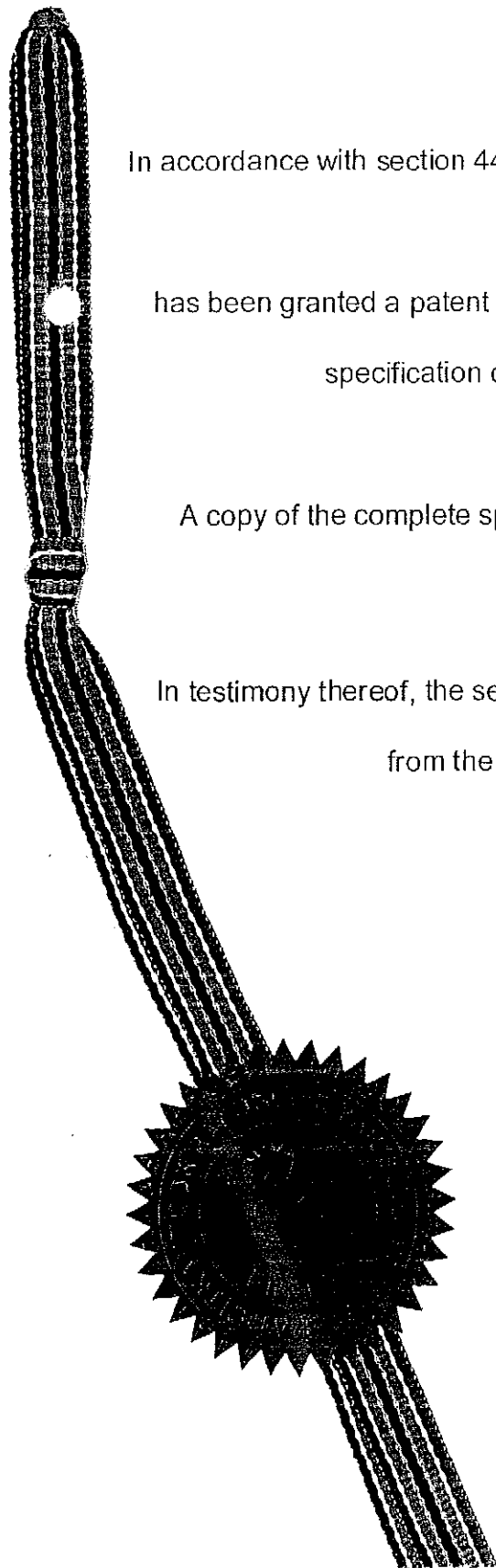

REPUBLIC OF SOUTH AFRICA

PATENTS ACT, 1978

REGISTER OF PATENTS

Official Application No.		Lodging date: Provisional		Acceptance date:	
21	01 2007/05597	22		47	25/04/2008
International classification		Lodging date: Complete		Granted date:	
51	C22B	23	9 JULY 2007		25/06/08

Full name(s) of applicant(s)/Patentee(s)

71 MINTEK

Applicant(s) substituted:

Date Registered:

71

Assignee(s):

Date Registered:

71

Full name(s) of inventor(s)

72 SCHOUKENS, Albert Francois Simon; CURR, Thomas Robert; ABDELLATIF, Masud; WHYTE, Rodney Murison

Priority claimed	Country	Number	Date
Note:	33 ZA	31 2005/0649	32 24 January 2005
Use International	33 (PCT)	31 (PCT/ZA2006/000011)	32 (24 January 2006)
Abbreviation for Country	33	31	32

Title of Invention:

54 METAL VAPOUR CONDENSATION AND LIQUID METAL WITHDRAWAL

Address of applicant(s)/patentee(s)

200 Hans Strijdom Drive, Randburg, 2194

Address for Service:

74 McCALLUM, RADEMEYER & FREIMOND, Maclyn House, 7 June Avenue, Bordeaux, Randburg • P.O. Box 1130, Randburg 2125

Patent of Addition to Patent No.:

Date of any change:

61

Fresh Application based on:

Date of any change:

(19) World Intellectual Property Organization
International Bureau



(43) International Publication Date
27 July 2006 (27.07.2006)

PCT

(10) International Publication Number
WO 2006/079125 A1

(51) International Patent Classification:
C22B 26/22 (2006.01) C22B 19/18 (2006.01)

(74) Agent: McCALLUM, RADEMEYER & FREIMOND;
Po Box 1130, Maclyn House, 7 June Avenue, 2125 Bordeaux, (ZA).

(21) International Application Number:
PCT/ZA2006/000011

(81) Designated States (unless otherwise indicated, for every kind of national protection available): AE, AG, AL, AM, AT, AU, AZ, BA, BB, BG, BR, BW, BY, BZ, CA, CH, CN, CO, CR, CU, CZ, DE, DK, DM, DZ, EC, EE, EG, ES, FI, GB, GD, GE, GH, GM, HR, HU, ID, IL, IN, IS, JP, KE, KG, KM, KN, KP, KR, KZ, LC, LK, LR, LS, LT, LU, LV, LY, MA, MD, MG, MK, MN, MW, MX, MZ, NA, NG, NI, NO, NZ, OM, PG, PH, PI, PT, RO, RU, SC, SD, SE, SG, SK, SL, SM, SY, TJ, TM, TN, TR, TT, TZ, UA, UG, US, UZ, VC, VN, YU, ZA, ZM, ZW.

(22) International Filing Date: 24 January 2006 (24.01.2006)

(25) Filing Language: English

(26) Publication Language: English

(30) Priority Data:
2005/0649 24 January 2005 (24.01.2005) ZA

(71) Applicant (for all designated States except US): MINTEK [ZA/ZA]; 200 Hans Strijdom Drive, 2125 Randburg (ZA).

(72) Inventors; and

(75) Inventors/Applicants (for US only): SCHOUKENS, Albert, Francois, Simon [ZA/ZA]; C/o 200 Hans Strijdom Drive, 2125 Randburg (ZA). CURR, Thomas, Robert [ZA/ZA]; C/o 200 Hans Strijdom Drive, 2125 Randburg (ZA). ABDELLATIF, Masud [ZA/ZA]; C/o 200 Hans Strijdom Drive, 2125 Randburg (ZA). WHYTE, Rodney, Murison [ZA/ZA]; C/o 200 Hans Strijdom Drive, 2125 Randburg (ZA).

(84) Designated States (unless otherwise indicated, for every kind of regional protection available): ARIPO (BW, GH, GM, KE, LS, MW, MZ, NA, SD, SI, SZ, TZ, UG, ZM, ZW), Eurasian (AM, AZ, BY, KG, KZ, MD, RU, TJ, TM), European (AT, BE, BG, CH, CY, CZ, DE, DK, EE, ES, FI, FR, GB, GR, HU, IE, IS, IT, LI, LU, LV, MC, NL, PL, PT, RO, SE, SI, SK, TR), OAPI (BF, BJ, CF, CG, CI, CM, GA, GN, GQ, GW, ML, MR, NE, SN, TD, TG).

Published:

— with international search report

[Continued on next page]

(54) Title: METAL VAPOUR CONDENSATION AND LIQUID METAL WITHDRAWAL

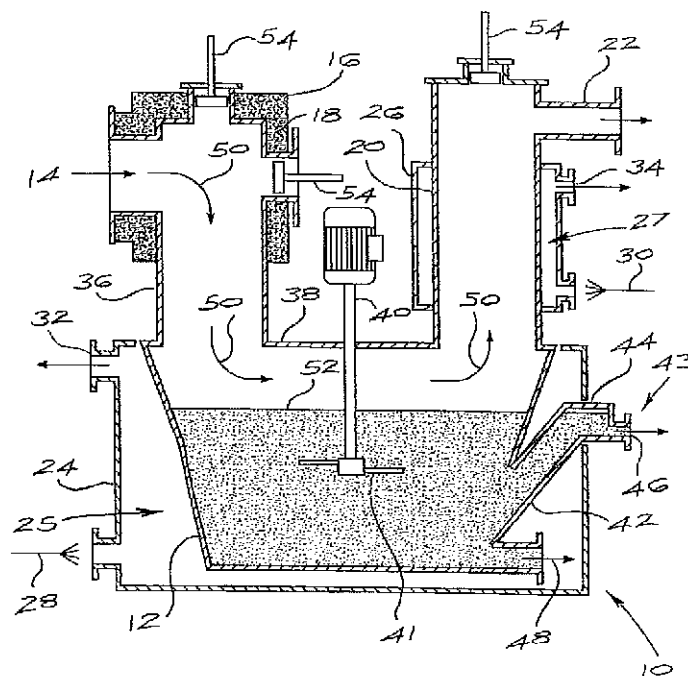

(57) Abstract: Liquid metal is continuously recovered by condensing metal vapour in a sealed system, more or less at atmospheric pressure, and collecting liquid metal in a crucible. The contents of the crucible are agitated and the temperature is controlled to prevent the liquid metal from solidifying. Liquid metal and dross are tapped from the crucible.

WO 2006/079125 A1



— *before the expiration of the time limit for amending the claims and to be republished in the event of receipt of amendments*

For two-letter codes and other abbreviations, refer to the "Guidance Notes on Codes and Abbreviations" appearing at the beginning of each regular issue of the PCT Gazette.

METAL VAPOUR CONDENSATION AND LIQUID METAL WITHDRAWALBACKGROUND OF THE INVENTION

[0001] This invention relates generally to the condensation of metal vapours, and to the continuous or semi-continuous withdrawal of liquid metal from a condenser.

5 [0002] The invention is described hereinafter with particular reference to the condensation of magnesium vapour, and the withdrawal of liquid magnesium from a condenser. It is to be understood that this is given by way of a non-limiting example and that the principles of the invention can be applied to other volatile metals such as zinc, calcium, sodium, potassium, and phosphorus.

10 [0003] The metallic vapour may be pure or it may be mixed with an inert gas such as argon, and it may contain dross, i.e. solid process contaminants, such as magnesium oxide.

[0004] US patent No 2,971,833 entitled "Process of Manufacturing Magnesium" (J. Artru et al) describes what is known as a Magnetherm furnace and condenser for the
15 manufacture of magnesium. The Magnetherm process involves the thermal production of magnesium vapour in a furnace and the condensation of the vapour in a condenser. The vapour is conducted to a condensation zone in the condenser where it is condensed as partly liquid and partly solid magnesium. The process is carried out under a vacuum of 2 kPa to 10 kPa and the condenser crucible is cooled
20 from the outside either by water-spray cooling or by immersion in a tank with circulating water. Since the furnace-condenser system is maintained under vacuum, and because the magnesium in the condenser is mostly solid, the process is

essentially a batch process which is repeated every 12 to 24 hours. The vacuum has to be broken to remove the slag periodically from the furnace and to replace the full condenser crucible with an empty one.

[0005] The product vapour generated in a thermal magnesium process such as the Magnetherm process inherently contains some undesirable solid particles of magnesium oxide, magnesium nitride, silicon oxide, calcium oxide, aluminium oxide, and carbon. The mixture of these solid particles is called dross. Most of the dross particles accumulate in the condenser crucible. In order to achieve continuous magnesium operation, a means of dross removal from the condenser has to be included in the design and the operating method of the condenser. The magnesium generating furnace may contain an underflow-overflow weir arrangement for continuous withdrawal of slag and residual ferrosilicon which are produced as by-products in the furnace to make the whole process of magnesium generation and condensation continuous.

[0006] It is an objective of this invention to provide a method and apparatus for continuous metal condensation and withdrawal of condensed liquid metal by operating at, or close to, atmospheric pressure, by suitable temperature control of the condenser, and by stirring of the condenser contents to allow continuous or semi-continuous withdrawal of metal from a condenser crucible.

SUMMARY OF THE INVENTION

[0007] The invention provides a method of condensing metal vapour which includes the steps of:

- (a) directing a stream of metal vapour at, or close to, atmospheric pressure into a sealed condenser apparatus which includes a receiving crucible;
- (b) controlling the temperature inside the crucible so that the metal vapour condenses, and is kept as liquid metal in the crucible;
- 5 (c) agitating the crucible contents of liquid metal and dross in order to pull in dross, metal vapour, and liquid metal droplets, to suspend the dross into the liquid metal, to dissipate energy of condensation and transfer this energy to side-walls of the crucible and into a heat transferring medium and so improve the efficiency of condensation; and
- 10 (d) tapping liquid metal and dross from the crucible as a slurry, without interrupting the production and condensation of metal vapour.

[0008] The dross may comprise solid particles of mainly metal oxides.

[0009] "Slurry", as used herein, designates a suspension or emulsion of dross in liquid metal.

15 **[0010]** The metal vapour may be the vapour of a volatile metal such as magnesium, zinc, calcium, sodium, potassium, and phosphorus. In the case of magnesium, the contaminants may be solids such as magnesium oxide, magnesium nitride, and silicon oxide.

[0011] In step (a) the stream may be directed at a controlled rate into the condenser apparatus. The metal vapour may be mixed with an inert gas such as argon, and with dross, i.e. solid particles such as magnesium oxide.

20

[0012] The metal vapour, in step (a), may have a pressure of from 0.7 to 1.2 atm.

[0013] The metal generating furnace may contain an underflow-overflow weir arrangement for continuous withdrawal of slag and residual ferrosilicon that are produced as by-products in the furnace to make the whole process of metal generation and condensation continuous.

5 [0014] In the case of magnesium the partial pressure of the magnesium vapour entering the condenser apparatus may be kept in the range of 0.7 to 1.2 atm. The partial pressure of the inert gas entering the condenser apparatus may be maintained in the range from 0 to 0.3 atm.

10 [0015] In step (b) the temperature inside the crucible may be controlled so that the vapour is condensed into liquid metal but so that the liquid metal is not allowed to solidify.

15 [0016] In step (c) the agitation (e.g. stirring) may be controlled so that the dross is suspended into the liquid metal to allow tapping of the mixture as a slurry. The agitation induces a uniform temperature distribution within the liquid metal bath by effectively dissipating the energy of condensation through side-walls of the crucible and into the heat transferring medium, which improves the efficiency of metal condensation.

20 [0017] A substantial temperature gradient may exist inside the complete furnace condenser system, including the connection between the furnace and the condenser crucible. For example, magnesium melts at a temperature of about 650°C, and is vaporised at about 1100°C. Clearly the magnesium vapour leaving the furnace has a temperature that is high enough to prevent magnesium condensation at the connection between the furnace and the inlet to the condenser apparatus. The liquid

magnesium in the condenser apparatus must be maintained at a temperature in excess of 650°C, but below 1100°C, which is the boiling point of magnesium.

5 [0018] The temperature inside the condenser apparatus may be controlled by circulating a heat transferring medium, through one or more jackets within the condenser apparatus or by using any other heat exchange device. The heat transferring medium may be a hot gas, ambient air, steam, a liquid metal, e.g. tin or lead, or a liquid salt or mixtures of salt such as mixtures of sodium chloride, potassium chloride, and magnesium chloride.

10 [0019] Initially the heat transferring medium may transfer heat from an external source to the condenser apparatus but thereafter, as the temperature of the condenser apparatus rises due to the intake and condensation of the metal vapour, heat may be extracted from the condenser apparatus and the heat transferring medium may be taking heat away from the condenser apparatus.

15 [0020] Agitation of the crucible contents may be effected by means of a stirrer with an impeller which is designed to create a vortex in order to pull solid particles and metal vapour and liquid droplets (fog or mist) into the melt. The desired flow and mixing pattern may be enhanced by installing baffles or fins in the condenser crucible.

20 [0021] The liquid metal and suspended solids may be tapped from the crucible in any appropriate way on a continuous or semi-continuous basis. For example the liquid metal and suspended solids may be tapped through an outlet pipe or may be siphoned from the crucible. Salt fluxes such as sodium chloride, potassium chloride,

magnesium chloride, aluminium fluoride, and cryolite may be added to the condenser to enhance magnesium tapping.

5 [0022] The invention also extends to a condenser apparatus for condensing metal vapour which comprises a receiving crucible, an elbow, a secondary condenser, an inlet through which metal vapour is directed through the elbow into the crucible, at least one temperature control arrangement for controlling temperatures inside the crucible, the elbow, and the secondary condenser so that the metal vapour condenses into liquid metal which is kept as liquid metal in the condenser apparatus, a mixing arrangement to suspend dross particles into liquid metal in the crucible and to dissipate energy of condensation, and an outlet through which liquid metal, mixed with dross, is drawn from the crucible.

[0023] Cleaning devices, such as plungers devices (e.g. sliding metal shafts with discs, actuated by hydraulics) may be used to keep passageways between the inlet and the outlet of the condenser apparatus open.

15 BRIEF DESCRIPTION OF THE DRAWING

[0024] The invention is further described by way of example with reference to the accompanying drawing which illustrates from a side and in cross section apparatus for condensing magnesium vapour according to the invention.

DESCRIPTION OF PREFERRED EMBODIMENT

20 [0025] The accompanying drawing illustrates a condenser apparatus 10, according to the invention, which includes a cylindrical receiver crucible 12 which is made of steel, an inlet 14 through which magnesium vapour is introduced into the condenser

apparatus and a condenser top section or elbow 16 which forms a connection between a furnace (not shown) and the crucible. Magnesium vapour, introduced at the inlet 14, may be mixed with an inert gas such as argon, and may contain solid particles such as magnesium oxide. A thermally insulating refractory material 18 is included in an upper part of the elbow 16.

[0026] A steel exit pipe 20 forms a secondary magnesium condenser, which terminates in a condenser outlet 22.

[0027] Sleeves or jackets 24 and 26 extend respectively around the crucible 12 and around the secondary condenser 20. The jackets are connected to temperature controlling devices (not shown) which, in this example, are based on the use of hot gas and cooling air. The inside of the crucible 12 is maintained at an appropriate temperature for condensation of magnesium vapour as liquid magnesium by blowing a heat transferring medium which, according to requirement, is either cooling air or hot combustion gases, tangentially into an annular space 25 between the jacket 24 and the crucible. Similarly by blowing cooling air or hot gas into an annular space 27 between the pipe 20 and the jacket 26, the inside of the secondary condenser 20 is maintained at a suitable temperature for condensation of magnesium vapour as liquid magnesium. Spirals may be located in the annular spaces around the crucible 12 and the pipe 20 to reduce any possible large temperature differences in these spaces.

[0028] The temperatures inside the crucible 12 and the secondary condenser 20 are maintained at 650°C to 750°C by regulating the supply of propane gas to burners 28 and 30, that are positioned to heat the crucible and the secondary condenser respectively. Heat can be extracted from the crucible and the secondary condenser

by blowing cooling air into the annular spaces 25 and 27 respectively, and so onto the walls of the crucible and the secondary condenser. When the flows of propane gas to the burners 28 and 30 are switched off, burner fans (not shown) can be used to blow cooling air into the annular spaces 25 and 27. The heat transferring medium exits the annular spaces via openings 32 and 34 for the crucible and the secondary condenser respectively.

[0029] The temperature control is thus effected at least by using heat exchanger principles. In this example a heat exchange device is formed by the jackets which enclose the spaces 25 and 27 through which the heat transfer medium is circulated. For a gas this can be done by using fans. When liquids are used suitable pumps are employed. Depending on circumstances liquid heat transferring mediums can be selected for example from tin, lead, sodium, potassium, and salts of sodium, potassium and magnesium, in molten form.

[0030] A lower part 36 of the elbow 16 and a roof 38 of the crucible can contain similar temperature controlling arrangements as the crucible and the secondary condenser. These components are not shown in the drawing.

[0031] The contents of the crucible are agitated by being stirred by a variable speed mixer 40 so as to suspend solid dross particles, such as magnesium oxide particles, into the liquid magnesium and, by so doing, to allow tapping of the mixture as an emulsion or slurry. An impeller 41 of the mixer is designed to create a vortex to pull magnesium vapour, liquid magnesium droplets, and solid particles of dross into the molten magnesium.

[0032] The crucible contains an underflow/overflow arrangement 43, consisting of an inclined spout 42 and an overflow box 44 with a tap hole 46, for continuous or semi-continuous tapping of the mixture of magnesium and dross. The spout 42 can also be used for siphoning liquid magnesium and dross from the crucible 12. Another tap hole 48 extends from a lower region of the crucible for draining of the magnesium-dross mixture from the crucible 12, when this is required for maintenance. The suspended solids are removed from the tapped liquid magnesium by co-melting with salt fluxes, which is known art.

[0033] The condenser apparatus is made airtight at its inlet 14 and outlet 22, at a port for the lower tap hole 48, at a connection between the crucible 12 and the elbow 16, and a connection between the crucible 12 and the secondary condenser 20, by means of high-temperature gaskets. These components are not shown for they are known in the art.

[0034] In use, a mixture of magnesium vapour, inert gas, and solid particles such as magnesium oxide, produced in a furnace, not shown, is supplied at a controlled rate to the condenser apparatus via the inlet 14. A furnace which is able to generate magnesium at atmospheric pressure, from magnesium-oxide containing feed materials, is described for example in US patent No. 4,699,653. Slag and residual ferrosilicon produced in the furnace may be tapped from the furnace on a semi-continuous or continuous basis, by means of an underflow-overflow weir arrangement, without interrupting the magnesium generation and condensation process. The partial pressure of the magnesium, entering the condenser apparatus, is kept in the range from 0.7 to 1.2 atm, while the partial pressure, at the inlet 14, of the inert gas, which normally is argon, is kept in the range of 0 to 0.3 atm. The

pressure in the condenser apparatus is atmospheric or close to atmospheric and normally is in the range of 0.7 to 1.2 atm.

5 [0035] The temperature of the mixture of magnesium vapour, inert gas and solid particles at the inlet 14, is above 1100°C. The gas is forced downwardly as is indicated by means of a succession of arrows 50. In a lower region of the elbow 16, and in an upper region of the crucible 12, the temperature is considerably reduced and the vapour is liquified to a large extent. The magnesium that condenses in the elbow 16 runs into the crucible.

10 [0036] The secondary condenser 20 is designed to recover at least part of the vapour which is not liquified. The magnesium condensed in the secondary condenser runs back into the crucible.

15 [0037] Liquid magnesium droplets (fog or mist), magnesium vapour, and dross (mostly magnesium oxide) are drawn into a bath 52, in the crucible, which contains mainly liquid magnesium, and the dross is suspended into the liquid magnesium. As stated, the impeller 41 is designed to create a vortex and so to pull in magnesium and dross efficiently. During operation, the magnesium bath level is kept between the bottom and an upper level of the overflow box 44. The magnesium bath level has to be contained within a narrow range for effective operation of the mixer. A number of fins or baffles (not shown), are located on an inner side of the crucible, to break up
20 centrifugal motion that is induced in the liquid metal by the stirrer 40 and to enhance mixing.

[0038] The condensate is tapped from the magnesium tap hole 46, either continuously or intermittently, for example each time when an upper level is reached

in the overflow box 44. Three plunger devices 54 (in this case: sliding metal shafts with discs, actuated hydraulically) are used for the cleaning of possible deposits in the inlet pipe 14, in the elbow, and in the secondary condenser, thereby to keep passageways in the condenser apparatus open.

5 [0039] The temperature of the condensed magnesium, inside the crucible, is kept at a level above the melting point of the magnesium; the interior of the condenser apparatus is maintained at, or near to, atmospheric pressure; and the dross is kept suspended in the molten magnesium. It is therefore possible to tap the condensed metal and dross 52 continuously or semi-continuously from the condenser apparatus
10 through the tap hole 46, without interrupting metal vapour production and subsequent condensation. Internal surface areas of the crucible, the secondary condenser and the elbow are designed to provide sufficient surface area for effective condensing.

[0040] The design is such that in use of the condenser apparatus the level of the magnesium bath inside the crucible allows for efficient mixing of liquid magnesium and dross, and to effect a required degree of heat transfer from the inside of the
15 condenser apparatus to the heat transferring medium.

EXAMPLE OF THE INVENTION

[0041] A test was conducted using condenser apparatus as shown in the drawing.

[0042] A mixture of magnesium vapour and argon gas was supplied at a controlled
20 rate of about 75 kg/h magnesium vapour and 5 kg/h argon gas to the condenser apparatus, via the inlet 14, for a period of approximately 50 hours. The furnace used to generate the magnesium vapour at atmospheric pressure, and essentially as described in US patent No 4,699,653 is not shown in the drawing. The partial

pressure of magnesium at the inlet, was kept at about 0.82 atm, while the partial pressure of argon; at the inlet, was kept at about 0.03 atm, taking into account that the atmospheric pressure at the location of the test was approximately 0.85 atm.

5 [0043] About 1200 kg of magnesium ingots were heated up and kept molten inside the crucible 12 during the starting up phase by means of the propane burner 28. This magnesium was used to bring the level of liquid magnesium inside the crucible above the level of the impeller of the stirrer 40 in order to allow stirring of the crucible contents, and up to a minimum height in the inclined spout 42 to create a seal of liquid magnesium at the inclined spout. When supplying magnesium vapour to the
10 condenser apparatus, the temperature inside the crucible was kept in the region of 650°C to 750°C by controlling the temperature of the gas which was blown through the annular space 25. This was achieved by adjusting the flow of propane gas to the burner, or the volume of cooling air which was blown into the annular space 25. At a relatively low flow of magnesium vapour to the condenser apparatus, usually no
15 cooling air was required to maintain the contents of the crucible at a temperature above 650°C, which is the melting point of magnesium, and hot combustion gases were normally blown around the crucible at controlled rates.

20 [0044] Temperatures were measured inside the crucible and at its side-walls, at different positions, by means of thermocouples. A substantially uniform temperature distribution was maintained throughout the crucible and its side-walls, with maximum measured temperature differences being 10°C. This results mainly from the design of the impeller 41, and the operation of the stirrer.

WO 2006/079125 PCT/ZA2006/000011
The temperature of the secondary condenser 20 was maintained at between 650°C and 700°C, by using hot gas or cooling air through the space 27, in the same way as temperature control inside the crucible was achieved.

5 [0046] The rotational speed of the stirrer 40 was variable between 40 rpm and 140 rpm and the stirrer was usually operated at 60 rpm to 80 rpm to achieve efficient mixing of the crucible contents, to enhance condensation by pulling in magnesium vapour and droplets, and to dissipate energy of condensation through the crucible side-walls.

10 [0047] Liquid magnesium and suspended solids (dross of mainly magnesium oxide particles) were tapped periodically from the crucible via the tap hole 46. During the 50 hours that magnesium vapour was supplied to the crucible, about 3500 kg crude magnesium, i.e. magnesium with 3 to 8 per cent (mass %) suspended dross particles, was tapped from the crucible. The efficiency of magnesium condensation was about 85 per cent. The efficiency of magnesium condensation is calculated as
15 follows: mass of magnesium metal tapped from the crucible as a fraction of the mass of magnesium in the gas leaving the furnace; mass of magnesium in the gas leaving the furnace being the mass of magnesium in the feed to the furnace minus the mass of magnesium in the slag tapped from the furnace. In an earlier test using an
20 apparatus similar to the apparatus 10 but without using a stirrer, the efficiency of magnesium condensation was only about 75 per cent. The plunger devices 54, actuated by hydraulics, were used as required to keep the passageways between the inlet and the outlet of the condenser apparatus open.

[0048] The facility provided by the present invention of being able to tap liquid magnesium continuously or semi-continuously from the crucible, without interrupting

WO 2006/079125
magnesium vapour production, should be contrasted with the situation which prevails in a **PCT/ZA2006/000011**
conventional Magnetherm process wherein the magnesium vapour is condensed
mainly as solid magnesium. In that process when the condenser crucible is filled
with magnesium, the magnesium generating process is stopped, the vacuum is
5 broken, the full crucible is removed, and an empty crucible is connected to the
magnesium generating furnace. Downtimes of more than 20% of the total operating
time are experienced in the Magnetherm process mainly due to the batch-wise
operation of the condenser.

CLAIMS

1. A method for condensing metal vapour which includes the steps of:
- (a) directing a stream of metal vapour at, or close to, atmospheric pressure into a sealed condenser apparatus which includes a receiving crucible;
 - 5 (b) controlling the temperature inside the receiving crucible so that the metal vapour condenses and is kept as liquid metal in the crucible;
 - (c) agitating the crucible contents of liquid metal and dross in order to pull in dross, metal vapour, and liquid metal droplets, to suspend the dross into the liquid metal, to dissipate energy of condensation and transfer
10 this energy to side-walls of the crucible and into a heat transferring medium and so improve the efficiency of condensation; and
 - (d) tapping liquid metal and dross from the crucible as a slurry, without interrupting production and condensation of metal vapour.
- 15 2. A method according to claim 1 wherein the metal vapour is selected from magnesium, zinc, calcium, sodium, potassium, and phosphorus vapour.
3. A method according to claim 1 or 2 wherein, in step (a), the stream is directed at a controlled rate into the condenser apparatus.
- 20 4. A method according to any one of claims 1 to 3 wherein the metal vapour is mixed with an inert gas, and contains solid particles of dross.
5. A method according to any one of claims 1 to 4 wherein the dross comprises solid particles of mainly metal oxides.

6. A method according to any one of claims 1 to 5 wherein, in step (b), the temperature inside the crucible is controlled so that the metal vapour is condensed but so that the liquid metal is not allowed to solidify.
- 5 7. A method according to any one of claims 1 to 6 which includes the step of controlling the temperatures inside the crucible, an inlet to the crucible, and a secondary condenser by circulating the heat transferring medium through at least one enclosed space around the condenser apparatus.
- 10 8. A method according to any one of claims 1 to 7 wherein in step (d) liquid metal and suspended dross are tapped from the crucible on a continuous or semi-continuous basis.
- 15 9. A method according to any one of claims 1 to 8 which is used for condensing magnesium vapour and wherein the partial pressure of the magnesium vapour, entering the condenser apparatus, is kept in the range of 0.7 to 1.2 atm.
- 20 10. A method according to claim 9 wherein the magnesium vapour is mixed with an inert gas, the partial pressure of which is maintained in the range from 0 to 0.3 atm.
- 25 11. Condenser apparatus for condensing metal vapour which comprises a receiving crucible, an elbow, and a secondary condenser, an inlet to the elbow through which metal vapour is directed into the crucible, at least one temperature control arrangement for controlling temperatures inside the

crucible, the elbow, and the secondary condenser so that the metal vapour condenses into liquid metal and is kept as liquid metal in the condenser apparatus, a mixing arrangement to suspend dross particles into liquid metal in the crucible and to dissipate energy of condensation, and an outlet from the crucible through which liquid metal, mixed with dross, is drawn.

5

12. Condenser apparatus according to claim 11 wherein the temperature control arrangement includes at least one heat exchange system which interacts with liquid metal inside the crucible and the secondary condenser, and a means for circulating a heat transferring medium through the heat exchange system.

10

13. Condenser apparatus according to claim 12 wherein the heat transferring medium is a forced flow of air or hot combustion gases.

15

14. Condenser apparatus according to claim 12 wherein the heat transferring medium is selected from molten tin, molten lead, molten sodium, molten potassium, and molten salts of sodium, potassium and magnesium.

20

15. Condenser apparatus according to any one of claims 12 to 14 wherein the heat transferring medium is used for heating an interior of the crucible, the elbow, and the secondary condenser, at least initially, and once the temperatures of the crucible and the secondary condenser have reached a desired operating state, for removing heat from the crucible, the elbow, and the secondary condenser.

25

16. Condenser apparatus according to claim 11 wherein the mixing arrangement includes at least one stirrer.
- 5 17. Condenser apparatus according to claim 16 wherein the stirrer has an impeller which is designed to create a vortex to pull magnesium vapour, liquid magnesium droplets, and solid particles of dross into the molten magnesium.
- 10 18. Condenser apparatus according to claim 16 or 17 wherein the stirrer induces a uniform temperature distribution into liquid metal inside the crucible, to improve the efficiency of magnesium condensation.
- 15 19. Condenser apparatus according to claim 15, 16, 17 or 18 which includes baffle plates inside the crucible to enhance the mixing.
- 20 20. Condenser apparatus according to any one of claims 11 to 19 which includes cleaning devices to keep passageways between the inlet and the outlet of the condenser apparatus open.
21. Condenser apparatus according to claim 20 wherein each cleaning device is a plunger device actuated by hydraulics.
22. Condenser apparatus according to any one of claims 11 to 21 which includes a gas outlet from the secondary condenser.

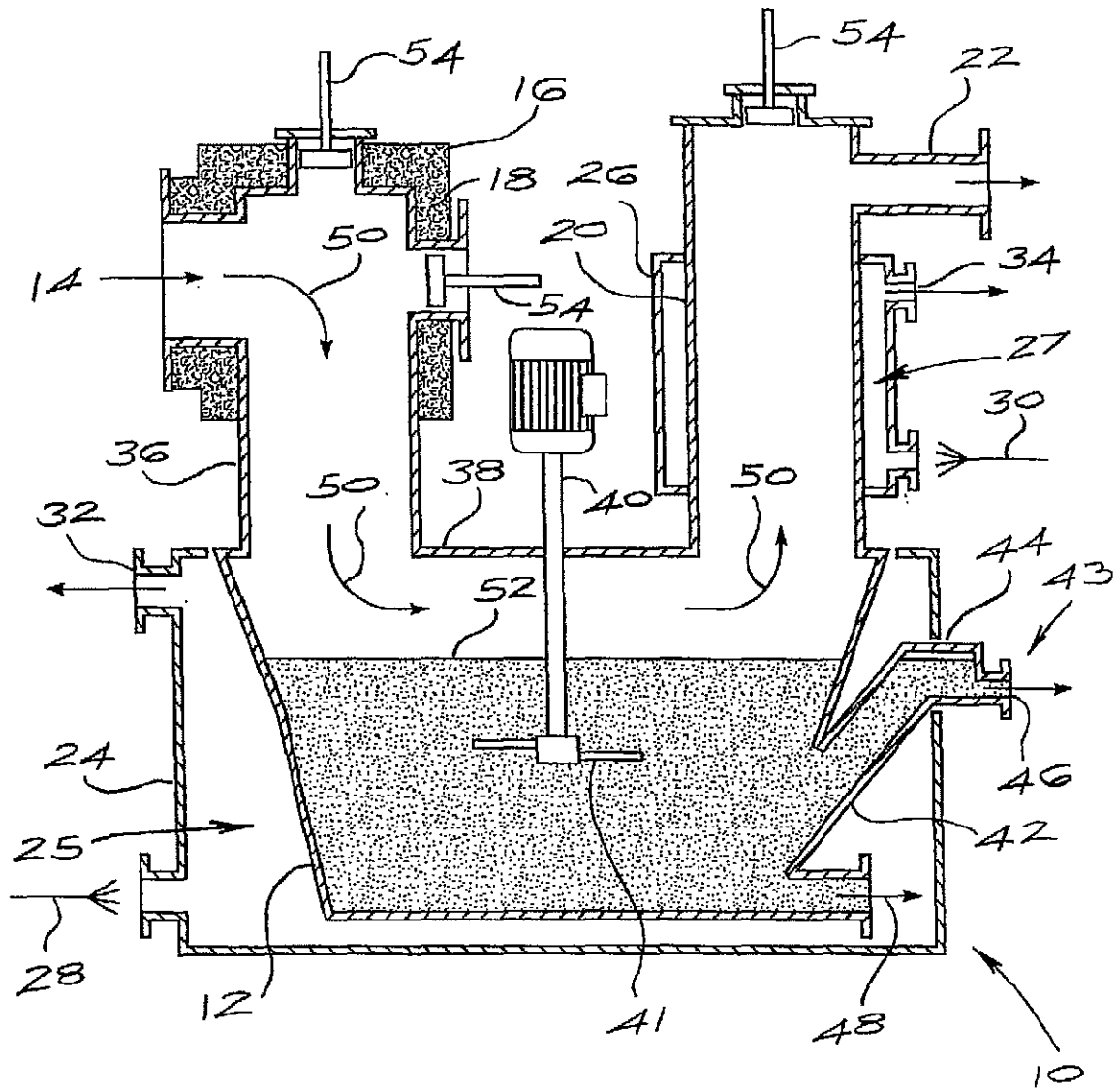

INTERNATIONAL SEARCH REPORT

International application No
PCT/ZA2006/000011

A. CLASSIFICATION OF SUBJECT MATTER
INV. C22B26/22 C22B19/18

According to International Patent Classification (IPC) or to both national classification and IPC

B. FIELDS SEARCHED

Minimum documentation searched (classification system followed by classification symbols)
C22B

Documentation searched other than minimum documentation to the extent that such documents are included in the fields searched

Electronic data base consulted during the international search (name of data base and, where practical, search terms used)

EPO-Internal

C. DOCUMENTS CONSIDERED TO BE RELEVANT

Category*	Citation of document, with indication, where appropriate, of the relevant passages	Relevant to claim No.
X	US 3 761 248 A (AVERY J,US) 25 September 1973 (1973-09-25)	1-22
Y	figure 3; column 6, line 37 - column 7, line 21; column 5, lines 33-35	1-22
X	US 2 473 304 A (ROBSON STANLEY) 14 June 1949 (1949-06-14)	1-22
Y	figure 1; column 6, line 33 - column 7, line 15	1-22
Y	WO 03/048398 A (MINTEK; SCHOUKENS, ALBERT, FRANCOIS, SIMON) 12 June 2003 (2003-06-12) the whole document	1-22
X	US 4 042 379 A (HARRIS ET AL) 16 August 1977 (1977-08-16) claim 6; column 2, lines 20-33	1
	----- -/--	

Further documents are listed in the continuation of Box C.

See patent family annex.

* Special categories of cited documents :

A document defining the general state of the art which is not considered to be of particular relevance

E earlier document but published on or after the international filing date

L document which may throw doubts on priority claim(s) or which is cited to establish the publication date of another citation or other special reason (as specified)

O document referring to an oral disclosure, use, exhibition or other means

P document published prior to the international filing date but later than the priority date claimed

T later document published after the international filing date or priority date and not in conflict with the application but cited to understand the principle or theory underlying the invention

X document of particular relevance; the claimed invention cannot be considered novel or cannot be considered to involve an inventive step when the document is taken alone

Y document of particular relevance; the claimed invention cannot be considered to involve an inventive step when the document is combined with one or more other such documents, such combination being obvious to a person skilled in the art.

Z document member of the same patent family

Date of the actual completion of the international search

22 May 2006

Date of mailing of the international search report

06/06/2006

Name and mailing address of the ISA/

European Patent Office, P.B. 5818 Patentlaan 2
NL - 2280 HV Rijswijk
Tel. (+31-70) 340-2040, Tx. 31 651 epo nl,
Fax: (+31-70) 340-3016

Authorized officer

Bjoerk, P

INTERNATIONAL SEARCH REPORT

International application No
PCT/ZA2006/000011

C(Continuation). DOCUMENTS CONSIDERED TO BE RELEVANT

Category*	Citation of document, with indication, where appropriate, of the relevant passages	Relevant to claim No.
A	GB 674 877 A (ROBERT FOUQUET) 2 July 1952 (1952-07-02) figure -----	1-22

INTERNATIONAL SEARCH REPORT

Information on patent family members

International application No

PCT/ZA2006/000011

Patent document cited in search report	Publication date	Publication date	Patent family member(s)	Publication date
US 3761248	A	25-09-1973	NONE	
US 2473304	A	14-06-1949	NONE	
WO 03048398	A	12-06-2003	AU 2002359902 A1	17-06-2003
US 4042379	A	16-08-1977	AR 207053 A1	09-09-1976
			AU 8501375 A	24-03-1977
			BG 26543 A3	12-04-1979
			BR 7506601 A	17-08-1976
			CA 1047259 A1	30-01-1979
			CS 209483 B2	31-12-1981
			DE 2544865 A1	29-04-1976
			ES 441674 A1	16-10-1977
			FR 2287515 A1	07-05-1976
			GB 1470417 A	14-04-1977
			HU 173091 B	28-02-1979
			IE 42165 B1	18-06-1980
			IN 143442 A1	26-11-1977
			IT 1043274 B	20-02-1980
			JP 1075787 C	25-12-1981
			JP 52070930 A	13-06-1977
			JP 56015695 B	11-04-1981
			NL 7511916 A	13-04-1976
			PL 101831 B1	28-02-1979
			RO 68541 A1	15-08-1980
			SU 606555 A3	05-05-1978
			TR 19668 A	05-10-1979
			ZA 7505860 A	25-08-1976
			ZM 13675 A1	21-04-1977
GB 674877	A	02-07-1952	NONE	

PATENT COOPERATION TREATY

PCT

INTERNATIONAL PRELIMINARY REPORT ON PATENTABILITY

(Chapter II of the Patent Cooperation Treaty)

(PCT Article 36 and Rule 70)

Applicant's or agent's file reference INT1179-MAJR		FOR FURTHER ACTION		See Form PCT/PEA/416
International application No. PCT/ZA2006/000011		International filing date (<i>day/month/year</i>) 24.01.2006		Priority date (<i>day/month/year</i>) 24.01.2005
International Patent Classification (IPC) or national classification and IPC INV. C22B26/22				
Applicant MINTEK				
<p>1. This report is the international preliminary examination report, established by this International Preliminary Examining Authority under Article 35 and transmitted to the applicant according to Article 36.</p> <p>2. This REPORT consists of a total of <u>6</u> sheets, including this cover sheet.</p> <p>3. This report is also accompanied by ANNEXES, comprising:</p> <p>a. <input checked="" type="checkbox"/> <i>sent to the applicant and to the International Bureau</i> a total of <u>2</u> sheets, as follows:</p> <p style="margin-left: 20px;"><input checked="" type="checkbox"/> sheets of the description, claims and/or drawings which have been amended and are the basis of this report and/or sheets containing rectifications authorized by this Authority (see Rule 70.16 and Section 607 of the Administrative Instructions).</p> <p style="margin-left: 20px;"><input type="checkbox"/> sheets which supersede earlier sheets, but which this Authority considers contain an amendment that goes beyond the disclosure in the international application as filed, as indicated in item 4 of Box No. I and the Supplemental Box.</p> <p>b. <input type="checkbox"/> (<i>sent to the International Bureau only</i>) a total of (indicate type and number of electronic carrier(s)) , containing a sequence listing and/or tables related thereto, in electronic form only, as indicated in the Supplemental Box Relating to Sequence Listing (see Section 802 of the Administrative Instructions).</p>				
<p>4. This report contains indications relating to the following items:</p> <p><input checked="" type="checkbox"/> Box No. I Basis of the report</p> <p><input type="checkbox"/> Box No. II Priority</p> <p><input type="checkbox"/> Box No. III Non-establishment of opinion with regard to novelty, inventive step and industrial applicability</p> <p><input type="checkbox"/> Box No. IV Lack of unity of invention</p> <p><input checked="" type="checkbox"/> Box No. V Reasoned statement under Article 35(2) with regard to novelty, inventive step or industrial applicability; citations and explanations supporting such statement</p> <p><input type="checkbox"/> Box No. VI Certain documents cited</p> <p><input type="checkbox"/> Box No. VII Certain defects in the international application</p> <p><input type="checkbox"/> Box No. VIII Certain observations on the international application</p>				
Date of submission of the demand 2006-11-22		Date of completion of this report 08.05.2007		
Name and mailing address of the international preliminary examining authority:  European Patent Office D-80298 Munich Tel. +49 89 2399 - 0 Tx: 523656 epmu d Fax: +49 89 2399 - 4465		Authorized officer Björk, Pia Telephone No. +49 89 2399-8452		



Box No. I Basis of the report

1. With regard to the **language**, this report is based on
- the international application in the language in which it was filed
 - a translation of the international application into , which is the language of a translation furnished for the purposes of:
 - international search (under Rules 12.3(a) and 23.1(b))
 - publication of the international application (under Rule 12.4(a))
 - international preliminary examination (under Rules 55.2(a) and/or 55.3(a))
2. With regard to the **elements*** of the international application, this report is based on (*replacement sheets which have been furnished to the receiving Office in response to an invitation under Article 14 are referred to in this report as "originally filed" and are not annexed to this report*):

Description, Pages

1-14 as originally filed

Claims, Numbers

1-10 filed with telefax on 22.11.2006

Drawings, Sheets

1/1 as originally filed

- a sequence listing and/or any related table(s) - see Supplemental Box Relating to Sequence Listing
3. The amendments have resulted in the cancellation of:
- the description, pages
 - the claims, Nos.
 - the drawings, sheets/figs
 - the sequence listing (*specify*):
 - any table(s) related to sequence listing (*specify*):
4. This report has been established as if (some of) the amendments annexed to this report and listed below had not been made, since they have been considered to go beyond the disclosure as filed, as indicated in the Supplemental Box (Rule 70.2(c)).
- the description, pages
 - the claims, Nos.
 - the drawings, sheets/figs
 - the sequence listing (*specify*):
 - any table(s) related to sequence listing (*specify*):

* If item 4 applies, some or all of these sheets may be marked "superseded."

**INTERNATIONAL PRELIMINARY REPORT
ON PATENTABILITY**

International application No.
PCT/ZA2006/000011

Box No. V Reasoned statement under Article 35(2) with regard to novelty, inventive step or industrial applicability; citations and explanations supporting such statement

1. Statement

Novelty (N)	Yes: Claims	<u>1-5,9</u>
	No: Claims	<u>6-8,10</u>
Inventive step (IS)	Yes: Claims	<u>1-5, 9</u>
	No: Claims	<u>6-8,10</u>
Industrial applicability (IA)	Yes: Claims	<u>1-10</u>
	No: Claims	

2. Citations and explanations (Rule 70.7):

see separate sheet

1. The application relates to a method and an apparatus for condensing metal vapour, such as magnesium (Mg) and zinc (Zn), whereby the metal vapour is condensed into liquid metal and the metal is stirred in such a way to obtain a slurry of liquid metal and dross.

Starting from the Magnetherm process of US-A-2 971 833, the claimed method allows a continuous withdrawal of a metal slurry compared to the solid metal obtained batchwise in the Magnetherm process. According to the description and in particular the examples, the stirring improves the Mg condensation by pulling in Mg vapour and droplets and dissipating energy of condensation (page 13).

2. **Amendments**

The application has been amended by focusing in claim 1 on the obtention of a slurry ("mixing the crucible contents of liquid metal and dross in order to suspend the dross within the liquid metal thereby forming a slurry"). A basis for this can be found in [0016] of the description. The removal of the effect of the stirring on the energy of dissipation is also seen as allowable as it is a result of the stirring and not a technical feature of the method as such (Art.34(2)(b) PCT).

In the apparatus claim the features of an elbow and a secondary condenser have been removed. These features are not essential for making the apparatus specifically adapted to the method of claims 1-5 and the amendment is therefore seen as allowable (Art.34(2)(b) PCT).

The feature of "an overflow box to contain the metal bath level within a narrow range for efficient operation of the mixing arrangement" has been introduced as dependent claim 7. Whereas the overflow box is described in the application as filed (for example in [0038]), the feature of "a narrow range (...) arrangement" is not directly derivable from the application as filed and thus not allowable with regard to Art.34(2)(b) PCT.

3. Reference is made to the following documents:

D1: US-A-3 761 248
D2: US-A-2 473 304
D3: WO-A-03/048398

D1 discloses a metallothermic production of Mg whereby Mg vapour is directed to a condenser 40 where the temperature is controlled by heating means 50 and the condensed Mg is maintained as liquid metal in the crucible 48. Figure 3 features a rotating paddle-wheel 74 with condensation surfaces 76 to pick up molten Mg droplets and thereby promote condensation. Other stirring means are also considered. The molten Mg is tapped at the outlet 52. An inert gas stream is used throughout the process (col.6, l.37 - col.7, l.21). The total pressure of the system, including the partial pressure of the inert gas is at least 0.1 atmosphere, preferably between 0.25 and 1.5 atmosphere (col.5, l.33-35).

D2 discloses a two-stage condenser for condensing Zn whereby Zn-bearing gases are introduced through a first elbow, molten Zn 5 is present in the first chamber 2 and a paddle-wheel 4 is provided to ensure that the entering gases are brought into contact with a spray of molten Zn. Liquid Zn can be run off continuously through an underflow weir 18. The second chamber 3 contains molten lead (Pb) to catch the remaining volatile Zn. The temperature is controlled either with cooling water in a jacket round the sump or by placing insulation bricks around chamber 2 (Fig.1; col.6, l.33 - col.7, l.15).

D3 originates from the present applicant and features a continuous method for condensing metallic vapour. D3 does not describe any stirring means for the molten metal.

4. The method of claim 1 is seen as novel over the disclosures of D1 to D3 insofar as the stirring means in D1 and D2 do not lead to a slurry being obtained. The paddle-wheel allows a larger contact surface between metal droplets and gas to improve condensation (see D1, col.7, l.16-21). D3 does not describe the obtention of a slurry

of liquid metal and dross and does not feature any stirring means. The requirement of Art.33(2) PCT is therefore fulfilled for the subject matter of claim 1 and of its dependent claims 2 to 5.

The apparatus of claim 6 features "a mixing arrangement to suspend dross particles into liquid metal in the crucible" and does not explicitly mention any slurry. The paddle-wheel of D1 and of D2 will achieve a slight degree of dross suspended in the liquid metal and each of these documents are therefore describing apparatuses which are novelty destroying to the subject matter of claim 6 (Art.33(2) PCT).

The introduction of the subject matter of dependent claim 9 into claim 6 would allow a novel and inventive distinction over D1 and D2.

5. There are no reference signs in the apparatus claims 6 to 10 (Rule 6.2(b) PCT).

CLAIMS

1. A method for continuously condensing metal vapour which includes a receiving crucible and which includes the steps of:

directing a stream of metal vapour at, or close to, atmospheric pressure into

5 a sealed condenser apparatus which includes a receiving crucible, and

controlling the temperature inside the receiving crucible so that the metal vapour condenses and is kept as liquid metal in the crucible and which is

characterized by the steps of:

mixing the crucible contents of liquid metal and dross in order to suspend

10 the dross within the liquid metal thereby forming a slurry; and

tapping the slurry of liquid metal and dross from the crucible, without interrupting the production of metal.

2. A method according to claim 1 wherein the metal vapour is selected from

15 magnesium, zinc, calcium, sodium, potassium, and phosphorus vapour.

3. A method according to claim 1 or 2 wherein the metal vapour is mixed with an inert gas, and contains solid particles of dross.

- 20 4. A method according to any one of claims 1 to 3 wherein the dross comprises solid particles of mainly metal oxides.

5. A method according to any one of claims 1 to 4 wherein liquid metal and suspended dross are tapped from the crucible on a continuous or semi-continuous basis.
- 5 6. Condenser apparatus for condensing metal vapour which includes a receiving crucible, an inlet through which metal vapour is directed into the crucible, at least one temperature control arrangement for controlling temperatures inside the crucible so that the metal vapour condenses into liquid metal, a mixing arrangement to suspend dross particles into liquid metal in the crucible, and an outlet from the crucible through which liquid metal, mixed with dross, is drawn.
- 10
7. Condenser apparatus according to claim 6 wherein the outlet of the receiving crucible includes an overflow box to contain the metal bath level within a narrow range for efficient operation of the mixing arrangement.
- 15
8. Condenser apparatus according to claim 6 or 7 wherein the mixing arrangement includes at least one stirrer.
- 20
9. Condenser apparatus according to claim 8 wherein the stirrer has an impeller which is designed to create a vortex to draw solid particles of dross into the molten metal.
- 25
10. Condenser apparatus according to any one of claims 6 to 9 which includes baffle plates inside the crucible to enhance the mixing.